

# ***EasyTravel***

## ***Lite***

## ***Easy-Light-Deluxe***



### **USER'S MANUAL**





Dear User,

Tzora Active Systems Ltd. thanks you for choosing the **EasyTravel Lite** scooter and wishes you safe and enjoyable journeys.

For proper operation and to maintain the scooter's operational readiness, we recommend that you read this user manual and all warning labels prior to using the scooter.



Kibbutz Tzora, 9980300, Israel

Tel: +972-2-9908207

Fax: +972-2-9991552

E-mail: [info@tzora.com](mailto:info@tzora.com)

Web site: [www.tzora.com](http://www.tzora.com)



# Table of Contents

## SECTION A – PRE-SALES INFORMATION

1	Introduction	6
2	Technical Data	7
3	Safety	11
4	System Components and Details	19

## SECTION B – USER INFORMATION

5	Unfolding and Folding Instructions	21
6	Operating the Scooter	25
7	Batteries and Charging	29
8	Storage and Transportation	33
9	Helpful Hints for Everyday Use	34
10	EMI – Electro-magnetic Interference	35

## SECTION C – SERVICE INFORMATION

11	General Maintenance and Inspections	42
12	Fault Finding	45
13	Disposal and Recycling	47
14	Wiring Diagram	48

**NOTE:** Design details may change without notice.

## **SECTION A – PRE-SALES INFORMATION**

**REMARK:** For people with impaired vision, this manual is available in digital format upon request from the manufacturer; please send an email to [info@tzora.com](mailto:info@tzora.com).

### **1. Introduction**

#### **Indications for Use**

The **EasyTravel Lite** is a mobility assistive device for indoor and outdoor use on mild terrain. It is not used as a transportation vehicle on roads and freeways used by cars.

#### **General Information**

The **EasyTravel Lite** is a “Class A” electrically powered scooter. It is intended to be used by individuals who are able to walk, but suffer from mobility limitations. The user must have sufficient arm and leg strength to get on and off the **EasyTravel Lite** alone and to safely steer under all driving conditions.

The occupant’s weight should not exceed 115 kg. (250 lbs.).

**CAUTION:** Failure to follow the instructions contained in this manual may result in injury to the user or to other persons.

#### **IMPORTANT:**

- **Charge the batteries for 24 hours before first use.**

## 2. Technical Data

Item	
Category	Class A
Maximum speed	Forward: Horizontal 6.0 km/h (3.7 mph) Downhill 3° 4.6 km/h (2.9 mph) Downhill 6° 4.9 km/h (3.0 mph) Uphill 3° 4.5 km/h (2.8 mph) Uphill 6° 3.5 km/h (2.2 mph) Reverse: Horizontal 2.8 km/h (1.7 mph)
Power supply	24V from 2 12V-12 A/h batteries
Charge time	7-10 hours
Estimated range	Lead acid battery: up to 13 km (8 mi) Lithium battery: up to 15 km (9.8 mi)
Estimated maneuvering range	Lead acid battery: up to 4.1 km (2.5 mi) Lithium battery: up to 4.7 km (3.1 mi)
Climbing slope	6° (10%)
Reversing width	1200 mm.
Curb (step) climbing	15 mm. (5/8 in.) max. (see note on page 14)
Ground clearance	4 cm. (1.6 in.)
Maximum load	115 kg. (250 lb.)
Liquid ingress protection	IPX4
Resistance to ignition of materials & assemblies	UL94 V-0 (burning of material stops within 10 seconds)
Scooter weight (excl. batteries)	21 kg. (46 lb.)
Scooter weight (incl. batteries)	Lead acid: 30 kg (66 lb.) Lithium: 25 kg (55 lb.)
Seat Weight	6 kg (13 lbs)
Battery pack weight	Lead acid: 8 kg (18 lb.) Lithium: 4.5 kg (10 lb.)
Front Wheels	200x50 mm (8x2 in.)
Rear Wheels	200x50 mm (8x2 in.)
Tire type	Flat-free PU
Dimensions (LxWxH)	101x57x90 cm. (39"x22"x35")

<b>Disclosure Information per ISO 7176-15:1996</b>		
<b>Item</b>	<b>Min</b>	<b>Max</b>
Overall length with legrest	-	1010 mm
Overall width	-	570 mm
Folded length	-	1010 mm
Folded width	-	570 mm
Folded height	-	520 mm
Total mass	-	30 kg
Mass of the heaviest part	-	21 kg
Static stability downhill	-	6°
Static stability uphill	-	6°
Static stability sideways	-	6°
Energy consumption	-	15 km
Dynamic stability uphill	-	3°
Obstacle climbing	-	15 mm
Maximum speed forward	-	6 km/h
Minimum braking distance from max speed	-	92 mm
Seat plane angle	3°	5°
Effective seat depth	420 mm	440 mm
Effective seat width		440 mm
Seat surface height at front edge	500 mm	510 mm
Backrest angle	10°	12°
Backrest height	360 mm	370 mm
Footrest to seat distance	380 mm	390 mm
Leg to seat surface angle	10°	12°
Armrest to seat distance	170 mm	180 mm
Front location of armrest structure	N/A	N/A
Handrim diameter	N/A	N/A
Horizontal location of axle	N/A	N/A
Minimum turning radius	900 mm	-

The batteries and charger comply with the safety requirements of ISO 7176-25:2013.



<b>MOTOR</b>	
Rated Voltage	24 V
Power	180 W

<b>LEAD ACID BATTERY</b>	
Manufacturer	Kung Long Batteries Industrial Co., Ltd. No. 6, Tzu-Li 3 Road, Nantou City, Taiwan
Model	WP12-12
Type	Rechargeable Sealed Lead Acid Battery
Nominal Capacity	20hour rate ( 0.6A to 10.50V ) 12A/h
Charge Retention (shelf life) at 20°C (68°F)	1 month 92% 3 month 90% 6 month 80%
Life expectancy:	Cycle Use: 100% depth of discharge 200 cycles 80% depth of discharge 225 cycles 50% depth of discharge 500 cycles Standby Use: 3~5years
No. of batteries	2
Nominal Voltage	12 V
Power	12A/h
Weight	Approx. 4.075kg (8.96 lbs.)

<b>LEAD ACID BATTERY CHARGER</b>	
Type	Off-board
Input	100-240VAC 50/60Hz 1.2-0.5A
Output	24VDC 2A
Charging temperature range	0°C to +40°C

See Chapter 7 for more information on the batteries and chargers.

<b>LITHIUM ION BATTERY</b>	
Manufacturer	Tornado Science Groups Ltd. 1-1-104 Nankai Industrial Park, Nankai District, Tianjin, China
Model	TDFP-12V12Ah
Type	Rechargeable Lithium Battery
Nominal Capacity	20hour rate ( 0.6A to 10.50V ) 12A/h
Charge Retention (shelf life) at 20°C (68°F)	1 month 97% 3 month 91% 6 month 83%
Life expectancy:	Cycle Use: 80% depth of discharge >2000 cycles
No. of batteries	2
Nominal Voltage	12 V
Power	12A/h
Weight	Approx. 1.8 kg ( lbs.)

<b>LITHIUM ION BATTERY CHARGER</b>	
Type	Off-board
Input	100-240VAC 50/60Hz 1.2-0.5A
Output	24VDC 2A
Charging temperature range	0°C to +40°C

See Chapter 7 for more information on the batteries and chargers.

<b>BATTERY CHARGER CONNECTOR PINS</b>	
 <p>(1) RED (2) BLACK (3) BLUE</p>	<p>(1) + Positive (2) – Negative (3) Inhibit</p>

The batteries and charger comply with the safety requirements of ISO 7176-25:2013.

The ***EasyTravel Lite*** and its accessories have been designed, manufactured and tested in accordance with the specification of the following:

**DIRECTIVE: Medical devices 93/42 EEC**



### 3. Safety

- The **EasyTravel Lite** is intended to be operated by the occupant and used by individuals who are able to walk but suffer from mild mobility limitations. The user must have sufficient arm and leg strength to get on and off the scooter alone and the cognitive and visual ability to safely operate the scooter under all driving conditions. The occupant's weight should not exceed 115 kg. (250 lb.).
- The **EasyTravel Lite** is intended for indoor and restricted outdoor use on pavements or paved footpaths only during daylight hours. It does not have lights nor reflectors and therefore must not be used in the dark or in limited visibility conditions.

#### **Operation**

These safety considerations and tips will help you operate the scooter safely. The Scooter is a powerful electric vehicle, and the following rules will help you prevent personal injury and damage to your scooter.

- Make sure that your weight does not exceed the recommended weight limit of the scooter (see Technical Specifications).
- Do not carry passengers.
- Always ensure that the power is switched off, when getting on or off of the scooter.
- When getting on and off the scooter, do not step on the foot rest.
- At all times while driving, keep your feet on the foot rest.
- Be aware of the environment around you when choosing a desired speed. For indoor environments, we recommend that you select the slowest speed setting. For outdoor operation select a speed that is comfortable for you to control the scooter safely.
- Reduce speed when making sharp turns.
- The scooter is intended to be used on paved surfaces
- Do not use the scooter on heavy terrain, e.g., beaches, dunes, etc. This can cause the scooter to have difficulty driving or to get stuck.

- Do not switch off the power when the scooter is still moving forward. This will bring the scooter to an extremely abrupt stop.
- Avoid jerky stop/start motions as it will result in excessive battery drain and increased tire wear. To brake in an emergency, simply release the throttle control lever.
- Make sure the brake release lever is in driving mode prior to operation (see Figure 1).
- In “Freewheel” mode the scooter may be moved manually. If the operator is unable to reach the control lever, it may be adjusted by an assistant. See also “Moving the Scooter” on page 24.
- **WARNING!**- Do not attempt to move the “Brake Release Lever” to the “Freewheel” mode when the scooter is standing on a slope as the brake (EMB) is disabled and there is a risk of accident. (Figure 1)



**Figure 1**



- Make sure that the throttle control lever is in the centered position before switching the scooter on.
- If the automatic brake fails to work, the user should immediately turn the key-switch to the off position.
- Do not attempt to drive the scooter while it is charging as operation is inhibited.

## Ramps and Curbs (Sidewalks)

- Use extra caution when driving down a slope.
- Never drive across a slope.
- **DO NOT** turn sharply on a slope.
- **DO NOT** drive in reverse on a slope or on a bumpy surface.
- When driving over a curb or raised surface, make sure that the bottom of the scooter has sufficient clearance (see Technical Specifications).
- The **EasyTravel Lite** scooter requires some momentum to climb a curb (step). The curb should be approached from a "run up" distance of approximately 1 meter (3 ft.).
- No attempt should be made to ascend or descend a curb of a height greater than 15 mm. (5/8 in.)

## General Instructions

- **DO NOT** attempt to lift or move a power scooter by any of its removable parts. Personal injury and damage to the power scooter may result.
- The **EasyTravel Lite** does not have lights and reflectors and therefore must not be used in the dark or in limited visibility conditions
- **DO NOT** connect any electrical or mechanical devices to the scooter. Doing so may cause personal injury or damage to equipment, and voids the manufacturer's warranty.
- **DO NOT** operate your vehicle if it is not functioning properly. Contact your service center immediately.
- The **EasyTravel Lite** scooter is **NOT** intended to be used as a seat in a motor vehicle.
- When exposed to external sources of heat (e.g. sunlight) surface temperatures of the scooter can increase. Exercise caution before touching exposed surfaces.
- **DO NOT** perform stretching exercises, wheelies or other stunts with the scooter.
- **DO NOT** drive the scooter on a roadway.
- **DO NOT** use the scooter on an escalator.

- **DO NOT** use the scooter during weight training as the maximum loading may be exceeded and the stability of the scooter compromised.

### Influence of Medication or Alcohol

- Check with your physician if you are taking any medication that may affect your ability to operate your power scooter safely.
- **DO NOT** operate your vehicle while you are under the influence of alcohol, as it impairs your ability to operate your power scooter in a safe manner.

### Warning Labels

- Please read the warning labels situated on the front of the Tiller, behind the Battery (see Figure 2) and on the Controller Cover (Figure 3)



**Figure 2**



**Figure 3**

## Additional Comfort and Safety

- For additional comfort and safety, it is recommended that the user fastens the anterior pelvic support belt similar to that shown in the figure below.



**Figure 4**

## Important Note

There are a number of potential finger traps on the scooter as indicated below. The operator or his/her assistant should be aware of these and take particular care to avoid personal injury. (see Figures 5 & 6)



**Figure 5**



**Figure 6**



## The Type Plate

The Type Plate can be found on the front of the Tiller behind the Battery.



**Figure 7a**

This label contains the serial number of the **EasyTravel Lite**.

The serial number consists of 11 digits and one letter:

Example: Serial no. **11001803006X**

<b>1100</b>	<b>18</b>	<b>03</b>	<b>006</b>	<b>X</b>
1	2	3	4	5

1. Model: **EasyTravel Lite**
2. Year of manufacturing (last two digits of the year)
3. Month of manufacturing
4. Sequential number of batch
5. Letter identifying the manufacturing location

## Tire Size

The tire size is marked on each of the tires: 200x50 mm (8x2 in.).

## Legend:



Read this user manual and all labels before operating.



When this equipment is no longer operational it must be sent to a separate collection facility for recovery and recycling.



CE approved, complies with the Essential Requirements of the European Medical Device Directive 93/42/EEC



Type B equipment.



Read the warnings in this manual before operating.

## Motor Warning Label

The Motor Warning/Serial No. label can be found on the Motor at the rear of the chassis.



**Figure 7b**

## 4. System Components and Details

Your **EasyTravel Lite** power scooter comes partially disassembled for protection during shipment. After unpacking, please familiarize yourself with the following components (see Figures 8, 8A, 8B and 9).

- |                                 |   |
|---------------------------------|---|
| 1. Battery pack (detachable)    | 10. Rear Wheels   |
| 2. Tiller (foldable)            | 11. Utility Basket (holding capacity 20lbs/9kg)                             |
| 3. Tiller lock/release triggers | 12. Control Panel   |
| 4. Controller cover             | 13. Drive/EMB (Electro-magnetic Brake)                                      |
| 5. Charging socket              | 14. Transaxle Motor (Fig. 8A)   |
| 6. Front drive wheels           | 15. Electro-magnetic Brake (EMB) Release Lever (Freewheel Device) (Fig. 8A) |
| 7. Foot platform                | 16. Charger & Connecting Cables (Fig.8B & 8C)                               |
| 8. Seat shell                   |   |
| 9. Seat cushions                |   |



Figure 8

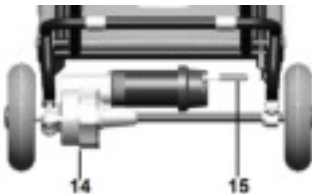

Figure 8A



Figure 8B

### Optional Accessories:

1. Extra battery pack
2. Optional battery charger (Fig. 8C) where Lithium batteries are used.

**WARNING:** When you are in possession of both a lead/acid **and** a lithium battery pack, the user must take extra care to use the **correct** charger for the specific battery pack being charged



**Figure 8C**

### Control Panel – (Figure 9)

1. On-Off Switch
2. Throttle control lever (right and left)
3. Speed adjusting knob
4. Indicator light (LED)
5. Battery Gauge
6. Hand-grips



**Figure 9**

## **SECTION B – USER INFORMATION**

### **5. Unfolding and Folding Instructions**

It is very easy to unfold or fold your scooter. Please follow the steps below. Contact your service center in any problems occur.

#### **Unfolding your *EasyTravel Lite***

1. Pull the Column Lock Triggers (Figure 8/3) and lift Steering Column from Seat (Figure 10)
2. Lift the Seat Backrest upright
3. Grasp top of Backrest and pull upwards to unfold the Seat Frame and let the Crossbar (Figure 12-A) fall into the Crossbar Supports (Figure 12-B)



**Figure 10**

#### **Folding your *EasyTravel Lite***

1. Grasp top of Backrest, lift it a little bit just to release the Crossbar (Figure 11-A) from the Supports (Figure 11-B) and fold the Seat Frame down
2. Fold Seat Backrest down
3. Pull Column Lock Triggers (Figure 8/3) and fold Column down over Seat (Figure 10)



**Figure 11**

## Positioning the Tiller (Figure 12)

The **EasyTravel Lite** allows you to adjust the tiller to maximize seating comfort and configure the scooter to your body structure. To adjust the angle of the front column, pull the column lock triggers upward. Move the column into the desired position and release. Push lightly back and forth on the column to ensure that it is locked in the desired position.

- For driving the **EasyTravel Lite**, adjust column to one of the two positions (Figure 12).

**CAUTION:** When getting in and out of the **EasyTravel Lite** seat, step only on the **CENTER** of the foot platform. **DO NOT STEP ON SIDE OF THE FOOT PLATFORM** to avoid tipping the **EasyTravel Lite**.



Drive position 1



Drive position 2

**Figure 12**

## Armrests (Figure 13)

To enable easier entry to and exit from your **EasyTravel** the armrest can be lifted (Figure 13).



**Figure 13**

## Installing the battery

Holding the battery case by the handle, place the v-shaped groove in the bottom of the battery case on the bar at the bottom of the Tiller. Rotate the Battery case towards the top of the tiller until the locating pins are opposite their housing. Release the handle, making sure that the locating pins fit securely in the housing (see Fig. 14).

**Note:** The batteries are partially charged. We recommend fully charging



**Figure 14**

## Installing the Basket

1. Place the Basket on the bent wire front support (underneath the seat) and the back of the tubular rear frame (see Fig. 15).



**Figure 15**

## Moving the Scooter

When moving the scooter (without operating it), be sure to follow these instructions:

1. Turn the power off.
2. Ensure that the Brake Release Lever is in Freewheel position  
(see Figure 8A).
3. Move the scooter carefully and slowly.
4. In order to park the scooter when in Freewheel mode, the Brake Release Lever must be moved to the Drive position.

**WARNING:** If the scooter is moved faster than a slow walking speed, the Controller will provide resistance power and the scooter will stop momentarily. After a few seconds the scooter can be moved again at a slow walking speed.

### Moving the Scooter in the Folded Position:

“Walking” your *EasyTravel Lite* in the folded position (Figure 16)

The folded *EasyTravel Lite* may be pulled along suitcase style (Figure 17). The battery may be carried in the utility basket.



**Figure 16**



**Figure 17**



## 6. Operating the Scooter

Operating the scooter is not complicated. However, we recommend reading these instructions prior to using the scooter, to ensure full understanding of the scooter operations.

**Note:** Be aware of the environment around you when choosing a desired speed. For indoor environments, we recommend that you select the slowest speed setting. For outdoor operation, select a speed that is comfortable for you to control safely.

### Control Panel

The control panel is located in the center of the tiller. It enables you to control the steering of the scooter, supplies information on the battery status, and shows fault warnings (see Fig. 18).



**Figure 18**

The following table details the various systems on the control panel:

Functionality	Description
1. Operating Key	Main On/Off switch (power source) for the <b><i>EasyTravel Lite</i></b> . (Remove the key when the scooter is not in use)
2. Operating Lever (Left/Right)	Moving the lever controls the speed. To drive forward, pull the right lever toward you and push the left lever away from you. Releasing the lever will bring the scooter to a gradually stop. To drive backward, pull the left lever towards you.
3. Manual Speed Adjuster	The maximum speed is 6 km/h (3.7 mph). Rotating the knob anti-clockwise to the lower speed will reduce the speed, for slower, gentle operation.
4. Operation Indicator	Shows operational faults (See Table of Faults)
5. Battery Charge Indicator	Shows the state of the battery whenever the scooter is operation.
6. Hand Grips	Flexible hand grips for comfortable hand support.

## **Battery Charge Indicator** (see Figure 18/5)

- Before the scooter is switched on, the indicating needle will be on the extreme left of the meter.
- When switched on with the batteries **fully** charged, the needle will be at the right of the green section.
- As power is used, the needle will move gradually towards the yellow and then the red section.
- If the needle reaches the yellow section, the batteries should be charged **as soon as possible**.
- If the needle reaches the red section, although some power remains, the batteries should be charged **immediately**.

**DO NOT** operate the scooter with depleted batteries, this may get you stranded.

**NOTE:** The indication is approximate and the user should allow a variation of  $\pm 10\%$ .

## **Suggestions for Safe Driving**

- For your own safety and the safety of others, always drive at a moderate speed.
- Releasing the operating handle will bring the scooter to a stop.
- Footpaths and sidewalks appear to be level but are usually slightly sloped for drainage of rainwater. Counter-steering may be necessary for overcoming excessive slopes. In such cases the speed should be reduced as necessary.
- When approaching ditches, bumps or similar obstacles - reduce speed as necessary.
- Do not operate EasyTravel Lite in places or on surfaces where a loss of wheel grip could be hazardous, for example on wet grassy slopes.
- When entering an elevator, drive in reverse so that you can then exit facing forward. Check that the elevator has stopped at the exact level of the floor.

- Ramps and Inclines

Operate with caution whenever going up or down a ramp or slope.

Lower the speed setting to a slow speed when climbing or descending inclines.

Lean forward and carefully manoeuvre your **EasyTravel Lite** up a ramp or incline. Be aware that not all ramps are constructed according to Government standards. The Government standard for wheelchair ramps is 2.5 cm (1 inch) rise per 30 cm (1 foot).

- Opening Doors

When a door opens towards you, approach at an angle and just off to one side. Adjust the speed knob to a low setting. Grasp the door knob, reverse and pull the door open. For doors that open away from you, position the front bumper against the door, close to the door jamb on the door knob side of the door. After you release the latch, use the bumper to push the door open.

**WARNING:** Be careful with glass doors to avoid personal injury!

## **7. Batteries and Charging**

The *EasyTravel Lite* scooter is programmed to work with sealed, maintenance-free 12V batteries.

**Note:** Turn off the scooter before removing or installing batteries.

Full charging of the batteries prior to usage helps keep them operational and lengthens their lifespan. Batteries can be charged at any time. The recommended charging time is 7-10 hours. Frequently over-charging (>12 hours) may shorten the lifespan.

**Note:** Do not use a car battery. Car batteries are not designed for the scooters and can be dangerous. Battery lifespan is influenced by treatment, number of recharges, storage and usage.

### **Charging the Battery**

The Battery Charger is an off-board universal type 100-240V, 50/60Hz. and should be plugged into a standard socket outlet.

**Note:** The battery cannot be charged if it completely discharged. It is recommended that you recharge when the battery gauge indicates so (the needle is in the yellow area), to prevent total discharge.

Remove the Battery Unit from the scooter. Plug the charger connector into the input socket on the back of the Battery Unit and then connect the charger to the power source.

The battery can also be charged while connected to the scooter. Plug the charger connector into the scooter input outlet (on the side of the tiller, see Fig. 8/5) and then connect the charger to the power source.

Driving or operation of the scooter is inhibited while the device is charging and should **NOT** be attempted.

**WARNING:** When you are in possession of both a lead/acid **and** a lithium battery pack, the user must take extra care to use the **correct** charger for the specific battery pack being charged.

While charging, the charging indicator light will be lit orange. When the batteries are fully charged, the indicator light will change to green. For maximum battery utilization, charge the battery overnight.

## Safety Instructions for Battery Charging

Follow these instructions to prevent damage or harm during charging:

- Make sure the scooter is turned off and the key removed before charging.
- Use the charger only for charging the scooter batteries.
- Charge the batteries in a well-ventilated area.
- Do not smoke near the batteries and keep away from source of heat or flames.
- Charge the batteries indoors or in a covered area, and avoid water.
- Always dry hands before charging.
- Remove jewelry before charging.
- Do not use charge cables that are damaged in any way.
- Do not carry the charger on the scooter.
- It is recommended that you change **both** batteries if they are weak.
- If you do not use the scooter for an extended period, be sure to charge the batteries at least once a month.
- It is recommended to charge the batteries overnight.

## Battery Storage

Before storing, make sure the battery packs are fully charged. When stored, bring out the batteries to charge at least once every 3 months.

Temperature for storage: -20°C to +40°C

Temperature for charging: 0°C to +40°C

Temperature for operation: -20°C to +50°C

**WARNING:** Store batteries in the 'correct' position, i.e. facing the same direction and not back-to-back: the contacts should not touch each other, this can cause depletion of the batteries. (See Figure 19).

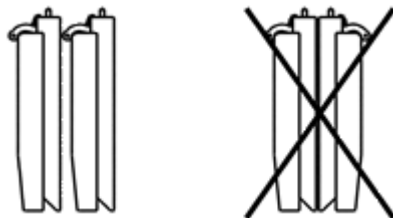

**Figure 19**

## Battery Troubleshooting

The battery indicator shows the battery status, and warns about problems by flashing.

Action	Description
Indicator is lit, with no flashing	System is operational
Slow flashing indicator	Charge the batteries as soon as possible
Quick flashing indicator	Trouble indicator. Perform the following actions: <ol style="list-style-type: none"><li>1. Turn off the scooter.</li><li>2. Make sure the rear wheels are locked.</li><li>3. Make sure the charger is disconnected from the scooter.</li><li>4. Make sure the operating lever is set in the middle. If the lever does not return to center, do not operate the scooter and contact your service center.</li><li>5. Turn the scooter on and begin driving.</li><li>6. If the indicator continues flashing quickly, count the number of flashes in each sequence, and check the specific problem in the Troubleshooting table at the end of this manual.</li></ol>

## Safety Measures

1. Read the directions before charging.
2. The charger is intended for indoor use, do not expose the charger to rain or other sources of moisture.
3. Explosive gasses can be generated while charging, keep the scooter and charger away from sources of ignition such as flames and sparks.
4. Charge in a well-ventilated area, in a space at least twice the size of the scooter, to prevent hazard due to build-up of flammable gasses.
5. Use only the manufacturer's recommended battery type.
6. Disconnect from the power source immediately upon completing charging.
7. The charger is an off-board charger, do not carry it on the scooter.

8. Each battery pack contains either 2 sealed lead acid batteries, or 2 lithium ion batteries.

9. Battery replacement should only be performed by an authorized agent.

**Note:** The lead acid batteries may emit a minimal amount of acid fumes. When removing batteries, always place them on cardboard, newspaper, or any other material that will prevent damage to the surface on which they stand.

### Battery Warning Label

- Please read the warning embossed on the back of the Battery Case (see Figure 20).



*Figure 20*



## 8. Storage and Transportation

### Transporting and Storing the Scooter

Your **EasyTravel Lite** scooter can be folded and transported inside medium and large size car trunks.

When preparing for transportation or storage:

1. Remove the basket.
2. Remove the battery.
3. For storage – set down in a stable position.
4. For transportation, place **EasyTravel Lite** scooter and accessories in car trunk.

(see Figure 21)



**Figure 21**

## 9. Helpful Hints for everyday Use

Before using your *EasyTravel Lite* take the following precautions:

- Ensure that the frame parts are securely positioned.

### **Speed Controls**

Always operate your *EasyTravel Lite* at a reasonable speed for both your personal safety and others.

### **Stopping**

Dynamic braking will gradually bring your *EasyTravel Lite* to a stop when hand control lever is released.

### **Ramps and Inclines**

Lean forward and carefully manoeuvre your *EasyTravel Lite* up a ramp or incline. Be aware that not all ramps are constructed according to Government standards. The Government standard for wheelchair ramps is 2.5 cm (1 inch) rise per 30 cm (1 foot).

Lower the speed setting to a slow speed when descending inclines.

### **Using an elevator**

Backing into an elevator allows you to exit forward. Be sure that the elevator is level with the floor.

### **Opening Doors**

When a door opens towards you, approach at an angle and just off to one side. Adjust the speed control to a low setting. Grasp the doorknob, reverse and pull the door open. For doors that open away from you, position the front of the scooter against the door, close to the doorjamb on the doorknob side of the door. After you release the latch, use the scooter to push the door open.

**WARNING:** Be careful with glass doors to avoid personal injury!

## 10. EMI – Electro-magnetic Interference

**WARNING:** It is important that you read this information regarding the possible effects of electromagnetic interference on your *EasyTravel Lite*.

- The *EasyTravel Lite* scooter might disturb the operation of devices in its environment that emit electromagnetic fields (e.g. alarm systems, automatic doors, etc.).
- The driving performance of the *EasyTravel Lite* scooter can be influenced by electromagnetic fields (e.g. those emitted by portable telephones, electricity generators or high power sources).

### **Electromagnetic Interference (EMI) From Radio Wave Sources**

Motorized scooters may be susceptible to electromagnetic interference (EMI), which is interfering electromagnetic energy (EM) emitted from sources such as radio stations, TV stations, amateur radio (HAM) transmitters, two-way radios, and cellular phones. The interference (from radio wave sources) can cause scooters to release their brakes, come to a sudden stop, or move in an uncontrolled manner. It can also permanently damage a scooter's control system. The intensity of the interfering EM energy can be measured in volts per meter (V/m). Each Motorized scooter can resist EMI up to a certain intensity. This is called its "immunity level". The higher the immunity level, the greater the protection. The FDA has stated that all newly manufactured electric mobility vehicle models should have a resistance of at least 20 V/m, which would provide a reasonable degree of protection from the more common sources of radiated EMI.

Your *EasyTravel Lite* as shipped, with no further modification, has an immunity level of 20 V/m. This immunity was tested with the inclusion of these accessories: a utility basket with a spare battery-pack and the charger unit carried inside it.

**There are a number of sources of relatively intense electromagnetic fields in the everyday environment. Some of these sources are obvious and easy to avoid. Others are not apparent and exposure is**

**unavoidable. However, we believe that by following the warnings listed below, your risk to EMI will be minimized.**

The sources of radiated EMI can be broadly classified into three types:

- 1) **Hand-held portable transceivers** (transmitters-receivers) with the antenna mounted directly on the transmitting unit. Examples include citizens band (CB) radios, "walkie-talkies", security, fire, and police transceivers, cellular telephones, and other personal communication devices.  
  
\*\*NOTE: Some cellular telephones and similar devices transmit signals while they are ON, even when not being used;
- 2) **Medium-range mobile transceivers**, such as those used in police cars, fire trucks, ambulances, and taxis. These usually have the antenna mounted on the outside of the vehicle; and
- 3) **Long-range transmitters and transceivers**, such as commercial broadcast transmitters (radio and TV broadcast antenna towers) and amateur (HAM) radios.

**NOTE:** Other types of hand-held devices, such as cordless phones, laptop computers, AM/FM radios, TV sets, CD players, and cassette players, and small appliances, such as electric shavers and hair dryers, so far as we know, are not likely to cause EMI problems to motorized scooters.

### **Motorized scooter Electromagnetic Interference (EMI)**

Because EM energy rapidly becomes more intense as one moves closer to the transmitting antenna (source), the EM fields from hand-held radio wave sources (transceivers) are of special concern. It is possible to unintentionally bring high levels of EM energy very close to the motorized scooter's control system while using these devices. This can affect the scooter's movement and braking. Therefore, the warnings listed below are recommended to prevent possible interference with the control system of your ***EasyTravel Lite***.

## WARNINGS

Electromagnetic interference (EMI) from sources such as radio and TV stations, amateur radio (HAM) transmitters, two-way radios, and cellular phones can affect motorized scooters. Following the warnings listed below should reduce the chance of unintended brake release or powered wheelchair movement, which could result in serious injury.

- 1) Do not operate hand-held transceivers (transmitters-receivers), such as citizens band (CB) radios, or turn ON personal communication devices, such as cellular phones, while your **EasyTravel Lite** is turned ON;
- 2) Be aware of nearby transmitters, such as radio or TV stations, and try to avoid coming close to them;
- 3) If unintended movement or brake release occurs, turn your **EasyTravel Lite** power switch OFF as soon as it is safe to do so;
- 4) Be aware that adding accessories or components, or modifying your **EasyTravel Lite**, may make it more susceptible to EMI (Note: There is no easy way to evaluate their effect on the overall immunity of your **EasyTravel Lite**);
- 5) Report all incidents of unintended movement or brake release to your Authorized **EasyTravel Lite** dealer or service center, and note whether there is a source of EMI nearby.

Guidance and manufacturer's declaration - electromagnetic emissions for all  
ME EQUIPMENT and ME SYSTEM.

Table 1: Guidance and manufacturer's declaration – electromagnetic emissions		
The <b>EasyTravel Lite</b> is intended for use in the electromagnetic environment specified below. The customer or the user of the <b>EasyTravel Lite</b> should assure that it is used in such an environment.		
Emissions test	Compliance	Electromagnetic environment - guidance
RF emissions CISPR 11	Group 1	The <b>EasyTravel Lite</b> uses RF energy only for its internal function. Therefore, its RF emissions are very low and are not likely to cause any interference in nearby electronic equipment
RF emissions CISPR 11	Class B	The <b>EasyTravel Lite</b> is suitable for use in all establishments, including domestic establishments and those directly connected to the public low-voltage power supply network that supplies buildings used for domestic purposes
Harmonic emissions IEC 61000-3-2	A	
Voltage fluctuations/ Flicker emissions IEC 61000-3-3	Complies	

Guidance and manufacturer's declaration - electromagnetic immunity for all  
ME EQUIPMENT and ME SYSTEM.

Table 2:Guidance and manufacturer's declaration – electromagnetic immunity		
The <b>EasyTravel Lite</b> is intended for use in the electromagnetic environment specified below. The customer or the user of the <b>EasyTravel Lite</b> should assure that it is used in such an environment.		
Immunity test	Compliance level	Electromagnetic environment - guidance
Electrostatic Discharge(ESD) IEC 61000-4-2	$\pm 2\text{kV}$ , $\pm 4\text{kV}$ , $\pm 6\text{ kV}$ contact $\pm 2\text{kV}$ , $\pm 4\text{kV}$ , $\pm 8\text{kV}$ air	Floors should be wood, concrete or ceramic tile. If floors are covered with synthetic material, the relative humidity should be at least 30%.
Electrical fast transient/burst IEC 61000-4-4	$\pm 2\text{ kV}$ for power supply lines	Mains power quality should be that of a typical commercial or hospital environment
Surge IEC 61000-4-5	$\pm 1\text{ kV}$ lines to lines	Mains power quality should be that of a typical commercial or hospital environment.
Voltage dips, voltage interruptions IEC 61000-4-11	For 0,5 cycle: $>95\%$ dip in $U_T$ For 5 cycle: 60% dip in $U_T$ For 25 cycle: 30% dip in $U_T$ For 5 s: $>95\%$ dip in $U_T$	Mains power quality should be that of a typical commercial or hospital environment.
Power frequency (50/60Hz) magnetic field IEC 61000-4-8	30 A/m	Power frequency magnetic fields should be at levels characteristic of a typical location in a typical commercial or hospital environment
Note: $U_T$ is the a.c. mains voltage prior to application of the test level.		

Guidance and manufacturer's declaration – electromagnetic immunity for ME  
EQUIPMENT and ME SYSTEM that are not LIFE-SUPPORTING.

Table 3: Guidance and manufacturer's declaration – electromagnetic immunity		
The <b>EasyTravel Lite</b> is intended for use in the electromagnetic environment specified below. The customer or the user of the <b>EasyTravel Lite</b> should assure that it is used in such an environment.		
Immunity test	Compliance level	Electromagnetic environment-guidance
<p>Conducted RF IEC 61000-4-6</p>	<p>3 Vrms 150 kHz to 80MHz</p>	<p>Portable and mobile RF communications equipment should be used no closer to any part of the SYSTEM, including cables, than the recommended separation distance calculated from the equation applicable to the frequency of the transmitter.</p> <p>Recommended separation distance</p> $d = \left[ \frac{3.5}{V_1} \right] \sqrt{P}$ $d = \left[ \frac{3.5}{E_1} \right] \sqrt{P} \quad 80\text{MHz to } 800\text{MHz}$ $d = \left[ \frac{7}{E_1} \right] \sqrt{P} \quad 800\text{MHz to } 2.5\text{GHz}$
<p>Radiated RF IEC 61000-4-3</p>	<p>3 V/m 80MHz to 2.5GHz</p>	<p>Where <math>P</math> is the maximum output power rating of the transmitter in Watt (W) according to the transmitter manufacturer and <math>d</math> is the recommended separation distance in metres (m).</p> <p>Field strengths from fixed RF transmitters, as determined by an electromagnetic site survey, should be less than the compliance level in each frequency range.</p> <p>Interference may occur in the vicinity of equipment marked with the following symbol:</p> 



Recommended separation distances between portable and mobile RF communications equipment and the ME EQUIPMENT and ME SYSTEM – for ME EQUIPMENT and ME SYSTEM that are not LIFE-SUPPORTING.

Recommended separation distances between portable and mobile RF communications equipment and the <b>EasyTravel Lite</b>			
The <b>EasyTravel Lite</b> is intended for use in an electromagnetic environment in which radiated RF disturbances are controlled. The customer or the user of the <b>EasyTravel Lite</b> can help prevent electromagnetic interference by maintaining a minimum distance between portable and mobile RF communications equipment (transmitters) and the <b>EasyTravel Lite</b> as recommended below, according to the maximum output power of the communications equipment.			
Rated maximum output power of transmitter W	Separation distance according to frequency of transmitter m		
	150kHz to 80 MHz	80MHz to 800MHz	800MHz to 2.5GHz
	$d = \left[\frac{3.5}{V_1}\right]\sqrt{P}$	$d = \left[\frac{3.5}{E_1}\right]\sqrt{P}$	$d = \left[\frac{7}{E_1}\right]\sqrt{P}$
0.01	0.12	0.12	0.23
0.1	0.38	0.38	0.73
1	1.2	1.2	2.3
10	3.8	3.8	7.3
100	12	12	23

## **SECTION C – SERVICE INFORMATION**

### **11. General Maintenance and Inspections**

Your scooter requires only minimal maintenance. Like any motorized vehicle there are some maintenance operations that are required.

- Avoid driving the scooter in the rain. Keep the scooter covered and stored in a shaded and dry place, away from damp or wet areas. Keep the batteries away from sun and rain.
- Keep the scooter clean. Clean the seat using a moist cloth. You can use a mild carpet cleaner. Painted areas can be further protected using car wax. Do not get the electrical cables or connectors wet.

To ensure a long and trouble-free operating life, we recommend the following regular maintenance operations:

#### **Daily Checks**

- Visually inspect the vehicle and the wheel condition.
- Watch the battery status.
- Make sure the operation lever returns to neutral position after release.

#### **Weekly Checks**

- Operation lever check: pull the lever to maximum speed. Turn the key to the "on" position. The scooter should not move and the indicator light should flash. If the scooter moves at all, contact your service center.
- Braking check – perform this check on a flat area, away from any obstruction within 1 meter.
  - Turn on the scooter.
  - Pull the operation lever to the Forward driving position, until you hear a click. Release the brake. The scooter should move forward slightly.
  - Release the operation lever. Within a few seconds, you should hear the click of the brake locking.
  - In addition, repeat this check for reverse driving.
- Check for tire wear and damage.

## Semi-annual Checks

Apply a lubricant/cleaner (such as WD40 or similar) these locations:

- Column tilt lock pin and housing.
- Battery pack handle axis and lock pins.

Lightly apply Vaseline or similar lubricant to battery contact pins and springs on front column.

Check for tire wear and damage.

Check the wear and tear of the wheels.

## Annual Checks

- We recommend that an authorized technician perform the annual check. The technician will check functionality, all connections, the electric motor status and the battery condition. The technician will check the release mechanism of the XLR connectors on the charger cable and on the scooter for proper functioning.

## Fuse Replacement Instructions

A fuse protects the wiring and battery in the event of a short circuit. If your **EasyTravel** stops abruptly, check the fuse. If it has 'blown', check for overloads or short circuits.

The fuse is located inside the battery case. To replace the fuse, open screws (Figure 22/1) and remove cover (Figure 22/2). Remove the fuse (Figure 22/3) from its socket. If 'blown', replace with the same style and size (automotive "blade" type – 20 A). There is a spare fuse attached to the battery-pack cover.

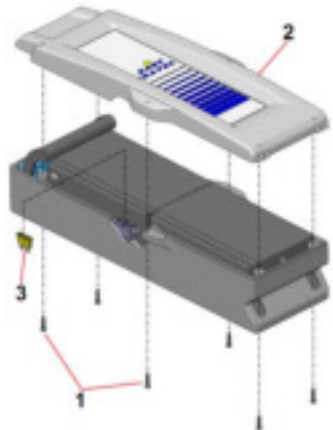

**Figure 22**

### **Periodic Checks**

Clean upholstery, plastic and metal parts with a mild surface cleaner. **Caution:** keep cleaning solvents away from electrical wires and connectors.

- Keep dirt out of the wheel axles, including lint, hair, sand and carpet fibers.
- Check for tire wear. If the tires are worn, replace them immediately.

**Warning: Do not attempt to repair or service the scooter or any of its components as this will void your warranty.**

**SERVICE AND REPAIR: CONTACT YOUR AUTHORIZED DEALER**

## 12. Fault Finding

Fault Description	Action
Scooter drives slowly, and indicator light flashes slowly	Batteries are low. Recharge the batteries.
Noises come from the motor and/or the wheels	Make sure no foreign objects or dirt is stuck in the wheels or wheel hubs. If you do not find any obstructions, contact the service center.
The scooter does not turn on	<ul style="list-style-type: none"><li>● Check that the key is inserted properly.</li><li>● Make sure that the batteries are inserted in the right position.</li><li>● Check the battery charge.</li></ul>
Batteries do not charge	<ul style="list-style-type: none"><li>● Check the connection between the charger and the scooter charge outlet.</li><li>● Make sure that the batteries are inserted in the right position.</li><li>● Make sure the charge indicator light is lit during charging..</li></ul>
The scooter turns on, but does not drive	<ul style="list-style-type: none"><li>● Make sure the wheel release handle is in drive position (See Fig. 1).</li><li>● Verify that there are no objects interfering with the scooter.</li><li>● Check the battery charge status.</li></ul>

If the scooter does not operate properly and the indicator light is flashing quickly, count the number of flashes in each sequence in order to define the problem in accordance with the table below.

Number of Flashes	Description
1	Either the battery needs charging or the batteries are not connected properly.
2	There is no connection to the motor. Check the connections between the motor and the controller.
3	There is a short circuit between the motor and the battery.
4	EMB Release Lever is engaged.
6	Check if the charger is connected.
7	Problem with the operation lever. Make sure it is set in the middle before operating the scooter.
8	Problem with the controller. Make sure all the connections into the control panel are tight and secure.
9	There is no connection between the controller and the brake. Make sure all connections to the brake and controller are tight and secure.
10	Controller overload. Likely a result of a failure in the battery connection. Check connections to the battery and controller.

### 13. Disposal and Recycling

- The packing material must be separated to plastic and paper/cardboard components and submitted to authorized recycling locations.
- The ***EasyTravel Lite*** scooter consists of electronic components, cables, plastic parts, steel and aluminium frame and adapter parts. Do not discard of any components to normal garbage facilities. When the ***EasyTravel Lite*** scooter is no longer operational, it is to be dismantled and separated into the above material groups and submitted to authorized recycling facilities.





## **WARRANTY**

The warranty period for the **EasyTravel Lite** is twelve months and covers faulty materials and workmanship (consumables not covered: tyres, upholstery, lamp bulbs, plastic coverings and batteries). Worn parts damaged as a result of excessive loading, improper handling, intentional damage or unauthorized maintenance or modifications are not covered by the warranty.

The expected life service of the **EasyTravel Lite** is approximately 5 years.

For safety and for warranty assurance reasons, any modifications and repair of the **EasyTravel Lite** or its components must be performed exclusively by authorized personnel and exclusively with original spare parts.



Kibbutz Tzora,  
99803, Israel  
Web site: [www.tzora.com](http://www.tzora.com)



MDI Europa GmbH  
Langenhagener Straße 71,  
D-30855 Langenhagen,  
Germany

**Distributed / Service and repair:**

